

Blue 12

Flow rate	Efficiency*
9.2 l/min	52,5%
12.5 l/min	47,5%

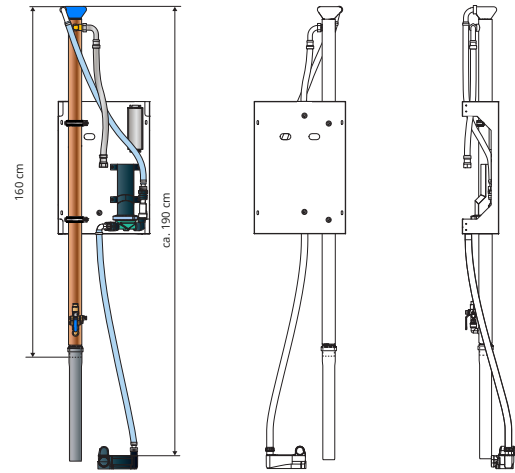

Blue 16

Flow rate	Efficiency*
9.2 l/min	57,5%
12.5 l/min	55,0%

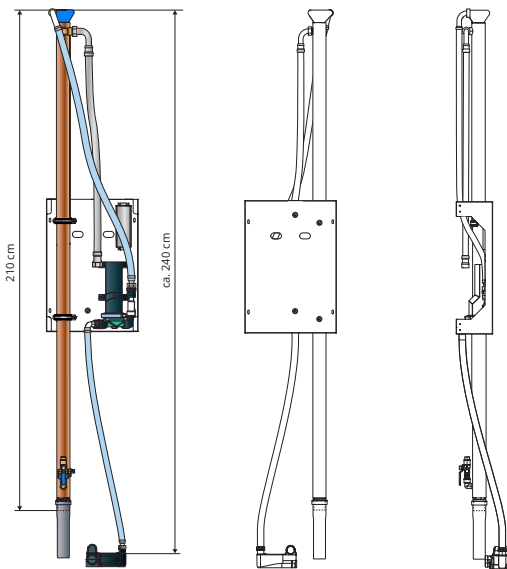

Blue 21

Flow rate	Efficiency*
9.2 l/min	62,5%
12.5 l/min	60,0%

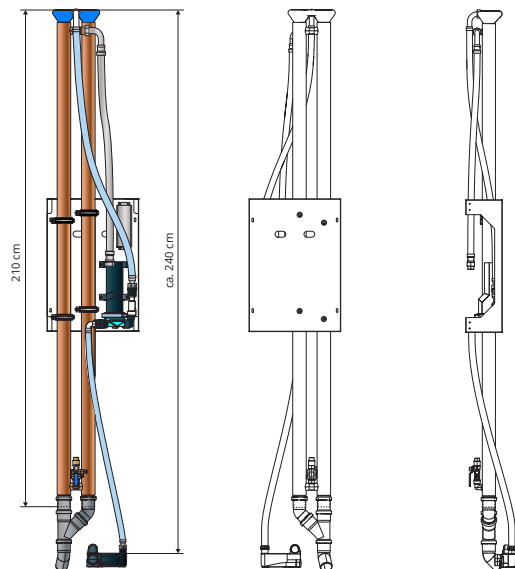

Blue HE

Flow rate	Efficiency*
9.2 l/min	72,5%
12.5 l/min	70,0%

Dimensions of the frame

- Width: 38 cm
- Depth: 15 cm
- Height: 55 cm

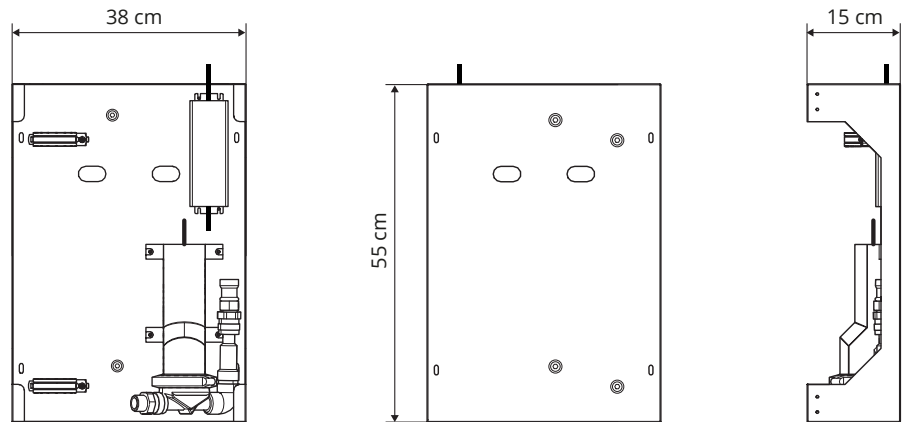

Connection systems

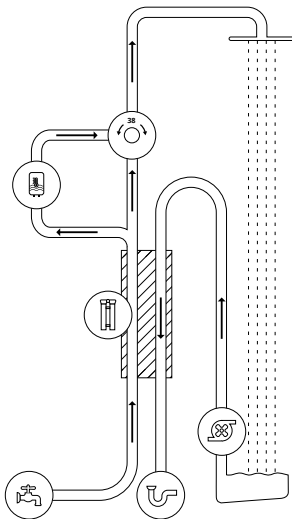

System A

(this is the most efficient connection method)

The heated tap water goes to the hot water supply and the shower thermostat.

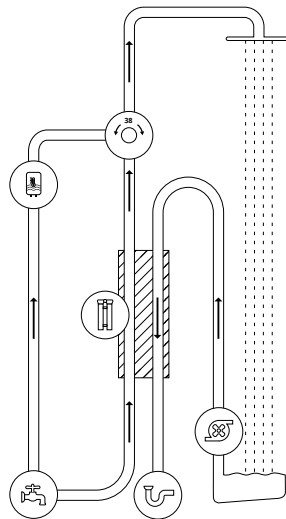

System B

(this is the most common connection method)

The heated tap water goes to the shower thermostatic tap.

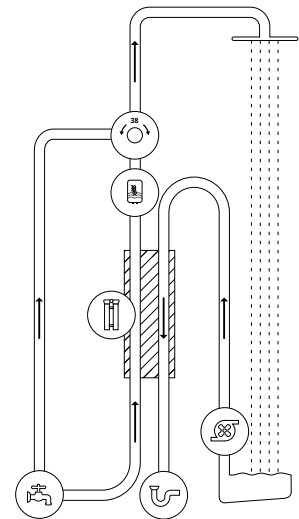

System C

(this is the least efficient connection method)

The heated tap water goes to the hot water supply.

Connection requirements

Hot water

- Connection via supplied 1/2 inch flexible hose, metal braided, female thread
- Maximum working pressure 5 bar
- Temperature at the water outlet maximum 70 °C

Cold water

- Connection via supplied 1/2 inch flexible hose, metal braided, female thread
- Maximum working pressure 5 bar

Absorbed power

- Maximum 42W in standard use
- <1W in standby
- Input voltage 90 - 305VAC, 12VDC
- 47 - 63Hz (with AC connection)
- Automatic overcurrent and surge protection

Other features

Suitable for

- Stacked housing
- New construction projects

Guarantee

- Standard 5 year warranty on all components**
- Extendable up to 8 years

**When installed for domestic use. Exceptions are mechanical damage to shower heads and glass plate.

Compliance and maintenance

- Complies with CE and SELV***
- Internal components IP45 or better (power supply and electronics IP67)
- Radiation: EN55015, EN61000-3-2 Class C (60% load); EN61000-3-3
- Immunity: EN61000-4-2,3,4,5,6,8,11, EN61547, EN55024, (surge 4KV), criteria A
- The wastewater heat recovery module meets the applicable KIWA requirements

***The Blue meets the Save Extra Low Voltage Standard (Very safe low voltage). If the Blue is used without a 12VDC power supply, you must ensure that the power supply used is SELV or complies with local regulations.

IP45/65

SELV

CE



kiwa

